



FIELD, ENGINEERING & AFTERMARKET SERVICES

CECO
ENVIRONMENTAL

Experts in field equipment, service and aftermarket supply.

ABOUT US

CECO Environmental (NASDAQ: CECO) is a leading environmentally focused, diversified industrial company whose solutions protect people, the environment and industrial equipment across the globe, serving a broad landscape of industrial air, industrial water and energy transition markets. We serve a wide range of applications and global customers through our key business segments: **Engineered Systems** and **Industrial Process Solutions**.

ENGINEERED SYSTEMS

Serving the power generation, refinery, water/wastewater and midstream oil and gas markets, we are a key part of helping meet the global demand for environmental and equipment protection through our highly engineered emissions management, product recovery, and water and gas separation solutions.

INDUSTRIAL PROCESS SOLUTIONS

Serving the broad industrial air pollution control, beverage can, fluid handling, electric vehicle production, food and beverage, semiconductor, process filtration, pharmaceutical, petrochemical, wastewater treatment, wood manufacturing, desalination and aquaculture markets. We protect the air we collectively breathe, maintain clean and safe operations for employees, lower energy consumption and minimize waste for customers, and ensure they meet regulatory compliance standards for toxic emissions, fumes, volatile organic compounds and odors.

NEED A SOLUTION? CONTACT US!

www.cecoenviro.com

CECO
ENVIRONMENTAL

Separation and Filtration Equipment

Peerless offers some of the most advanced and trusted process equipment on the market. We design and manufacture a wide range of filtration and two and three-phase separation solutions, utilizing various inertial, cyclonic and media-based proprietary technologies.

Peerless Separation and Filtration Products Include:

- Vane Separators
- Centrifugal Separators
- Filter/Separators
- Coalescing Separators
- Fuel Gas Skids



Selective Catalytic Reduction Systems

Peerless Selective Catalytic Reduction (SCR) technologies process exhaust systems, transforming Nitrogen Oxide (NOx) emissions into harmless nitrogen and water. Peerless SCR systems have been used for sources ranging from food production to power producers. Our expertise in NOx reduction has successfully been applied across a wide range of applications, such as Gas Turbines, Heat Recovery Steam Generators (HRSGs), Utility Boilers, Waste Incinerators, Process Heaters, Reformers and Cokers.

Peerless Designs and Manufactures SCRs For:

- Power Generation
- Refinery/Petrochemical
- Industrial

Oily Water Treatment

Peerless provides Skimovex Oily Water Treatment technology to meet the requirements of a comprehensive produced water management system.

Peerless Oil Water Treatment Water Products Include:

- CPI / TPI Separators
- Flotation Packages, Including Induced, Dissolved, and Compact Gas Flotation
- Deoiling/Desanding Hydrocyclones
- Nutshell and Media Filters



Marine Products

Peerless provides services that emphasize superior performance for the marine/offshore industry, including:

- Filtration and separation of salt-water aerosols for HVAC & gas turbine engine intakes.
- Patented systems using a weight-saving composite material with radar-absorbing options.

NEED A SOLUTION? CONTACT US!

www.cecoenviro.com

Acid Gas, Alkali Gas, Particulate Matter, Liquid Mist, Soluble Solids, Odor Control and Niche Chemical Contaminants Removal

HEE-Duall provides innovative solutions and a diverse line of products and technologies for the purification of air and the destruction of volatile organic compounds (VOCs), hazardous air pollutants (HAPs), water contaminants and process odors in both industrial and municipal applications. These technologies are designed to handle and treat harsh conditions like the handling and ventilation of corrosive air streams and gases, as well as mists and particulates.

HEE-Duall Abatement Products Include:

- Wet Scrubbers
- Mist Eliminators
- Aeration Towers/Degasifiers
- Corrosion Resistant Ducting
- Exhaust Fans
- Hoods



CECO Filters has been designing and manufacturing Mist Eliminator Systems used to abate corrosive mist and oil droplets from industrial air and gas streams for over 50 years. In addition to our in-house manufacturing facilities, CECO Filters provides repacking services, consultancy and testing to our customers across the globe.

CECO Filters Products Include:

Candle Filters or Fiber Bed Mist Eliminators

Mist Eliminator Systems (Chlor Alkali, Sulfuric Acid, Nitric Acid, and Ammonium Nitrate Applications)

Volatile Organic Compounds, Hazardous Air Pollutants and Odor Control

CECO Thermal Abatement Solutions custom designs and manufactures highly efficient thermal and catalytic abatement equipment and adsorption technologies. These systems are used to remove VOCs, gaseous toxic fumes, HAPs, odors from process emissions, hydrocarbons and acid gas process-laden streams. Consisting of two brands, **Adwest** and **EIS** have supplied solutions in some of the harshest environments and conditions across the globe.

CECO Thermal Abatement Products Include:

- Regenerative Thermal Oxidizers (RTO)
- VOC Concentrators
- Direct Fired Thermal Oxidizers (DFTO)
- Catalytic Oxidation Solutions



NEED A SOLUTION? CONTACT US!

www.cecoenviro.com

Particulate Matter (PM) Control and Product Recovery

Fisher-Klosterman's (FKI) expertise includes handling the most severe process conditions, such as high temperature, high pressure, and erosive particulate and corrosive gases. In addition, FKI can design for explosion venting/containment and provide complete engineered systems.

FKI Products Include:

- High-Efficiency Cyclones for Efficient Product Recovery
- Venturi Scrubbers
- MS Scrubber
- Severe Service Cyclones
- Multi-Purpose Scrubber

Since 1959, **Flex-Kleen** has been a leader in industrial process dust control, product recovery, nuisance dust collection and air pollution control for dozens of industries around the world. Flex-Kleen industrial dust collectors meet the most demanding technical challenges associated with corrosive environments, sanitary conditions, combustible dust and gases, hygroscopic materials, low bulk density materials, and materials that are under high temperature, high pressure, or high vacuum.

Flex-Kleen's specialized ASME & PED Products Include:

- Bin Vents
- CDCTM Cartridge Dust Collectors
- CT Series High Pressure/High Vacuum Dust Collectors
- HEPA Air Filtration Systems
- Pulse-Jet Dust Collectors
- SmartTimerTM



NEED A SOLUTION? CONTACT US!

www.cecoenviro.com

CECO Environmental – Field Services

CECO Environmental's Middle East office, headquartered in Dubai, offers a comprehensive range of aftermarket technical support throughout the entire life of our equipment, as well as equipment supplied by other manufacturers.

INSTALLATION SUPPORT

CECO partners with the customers to provide valuable technical support and engineering expertise. We provide information and oversight early in the procurement process to appropriately plan for this critical equipment lifecycle stage. CECO ensures that the equipment is installed correctly to set the stage for maximum reliability and efficiency throughout the equipment's lifecycle. Once on-site, we handle the complete installation of the equipment, including internal technology components.

TRAINING

We provide a dedicated training plan curated around the operators' responsibilities and site requirements. This plan includes customized equipment training, on-site equipment walk-throughs and even classroom sessions when requested. One of our dedicated field engineers does this training to ensure the most comprehensive and accurate guide.

COMMISSIONING & START-UP SUPERVISION

CECO's highly-trained technicians, field service engineers and supervisors review the installation and safety requirements before the start-up of the equipment. Operational targets are aligned with the original design to baseline the active running of the equipment. Our field team is capable of supporting multi-disciplinary requirements, including mechanical, process, electrical and instrumentation, automation and proprietary technology specialists.

REPAIR, INSPECTION & MAINTENANCE SERVICES

Our team of expert service technicians is available for various service offerings. From emergency repairs to preventative maintenance and pre-arranged service agreements, we ensure the equipment is running safely and efficiently to meet your operational needs. These services will help optimize the total cost of ownership, reduce the chance of unplanned downtime and keep your team safe.

Maintenance includes, but is not limited to:

- Inspection of internal components
- Assistance with filter elements
- Disassembly, change-out cleaning and re-installation of process internals

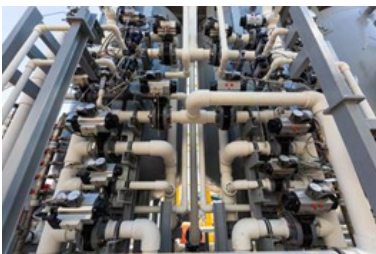

NEED A SOLUTION? CONTACT US!

www.cecoenviro.com

CECO
ENVIRONMENTAL

Equipment Assessment and Performance Checks

CECO assists in solving a variety of complex equipment problems. Our assessments will begin with trending and recording various system performance parameters, looking for patterns and issues. These assessments will help to solve ever-changing difficulties and provide an implementation plan for lowering operational costs and improving productivity and efficiency.

CECO offers a range of advanced, on-site process diagnostics using our specialized field-testing equipment, including:

- LISP - Laser Isokinetic Sampling Probe for analysis
- CSP - Compact Sampling Probe for analysis of bulk of liquid droplet and solid particulate sizes liquid and solids efficiencies contained in a gas stream

Upgrades, Retrofits and Modifications

We help our customers to optimize the total cost of operations. Whether it's a new production requirement, trying to extend the equipment's lifecycle, or improving operational efficiency, CECO can design and retrofit to the existing unit to fit unique needs and changing operating conditions. Retrofits are manufactured to the original equipment standards for quality and reliability.

Rental Equipment

Peerless understands that process plants often experience changing conditions, leading to operational issues and occasionally unplanned shutdowns. CECO offers our customers a variety of rental equipment for temporary use, allowing for time to find a more permanent solution.

Some of Our Rental Offerings Include:

- Filter Vessels
- Potable Water/Reverse Osmosis Systems
- Liquid-Liquid Coalescers
- Oily Water Separators



Pilot Plants

CECO offers a wide range of advanced technologies and field-capable slipstream trial units, allowing our customers to test the suitability of the technology in their plant, including:

- Filter Vessels, Liquid-Liquid Coalescers
- Hydrocyclones
- FeOxy Advanced Oxidation Process
- Compact Flotation
- Desanders

NEED A SOLUTION? CONTACT US!

www.cecoenviro.com

CECO Environmental – Aftermarket Parts

CECO Environmental supports our equipment in the field throughout the entire service life. We offer spare parts and consumables to ensure that our customers' equipment performs as designed.

Genuine OEM Spares, Consumables, Replacement Parts

CECO recommends that all customers keep appropriate quantities of genuine OEM spare parts and consumables for use during the life of the equipment. Genuine OEM spares, consumables and replacement parts for CECO equipment are designed to the original standards to maximize operational efficiency and provide maximum life expectancy. CECO, working with our customers and local partners, can customize a stocking plan to ensure that sufficient spares and consumables are available in-country as needed by plant operation and maintenance - this is especially important during start-up and commissioning. We typically supply these recommended parts with the capital equipment delivery or as a separate supply when needed. Having parts on hand avoids the chances of unplanned and costly downtime.

Available and recommended parts include, but are not limited to:

- Filter Elements, Gaskets, Fixed Bed Media, and Chemical
- Replacement Process Internals, Such as Vane Packs and Mesh Pads

Upgrades, Replacements & Retrofits

Peerless offers upgrades and retrofits for non-CECO equipment operating in the field. By providing replacement or upgraded filter elements, we can fix operating issues like the carryover of liquid and solid contamination, which can cause fouling or damage to downstream equipment.



NEED A SOLUTION? CONTACT US!

www.cecoenviro.com

CECO
ENVIRONMENTAL

CECO Environmental – Engineering Services

CECO Environmental offers engineering support during the design phase or as part of consultation and troubleshooting services.

Computation Fluid Dynamics (CFD)

CFD can be used to model the processing system enabling the visualization of pertinent process information. CFD is a highly effective and cost-efficient tool that can be used to replace expensive and time-consuming physical tests. Computational models reduce the need for extensive engineering. CECO has over 2 decades of utilizing fluent software to execute CFDs.

CFD Allows For:

- Multi-phase flow simulations
- Retrofit design evaluations
- Offshore motion simulations

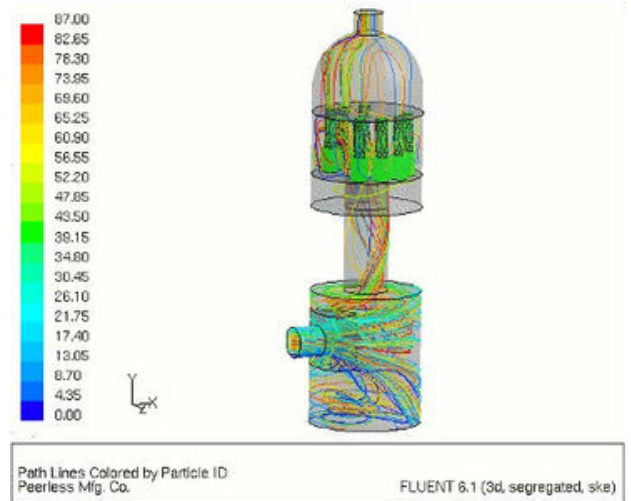

Laboratory Analysis

As part of our field service process and diagnostic services, CECO offers a wide range of laboratory services aimed at characterizing process contaminants to help our customers improve operations.

- Particle size distribution analysis of solid contaminants
- C-MS: Gas Chromatography-Mass Spectrometry
- Fourier Transform Infrared – Infrared Spectroscopy



NEED A SOLUTION? CONTACT US!

www.cecoenviro.com

CECO
ENVIRONMENTAL



GLOBAL HEADQUARTERS – U.S.A.

**14651 Dallas Parkway, Suite 500
Dallas, TX 75254**

**Phone: 214-357-6181
Info@OneCECO.com**

CONTACT US

**Dubai, United Arab Emirates
+971 (0) 4434 0004**

**Stansted, Essex, United Kingdom
+44-1439-330623**

**Singapore
+65-6472-0020**

**Shanghai, China
+86-21-62560387**

NEED A SOLUTION? CONTACT US!

www.cecoenviro.com

CECO
ENVIRONMENTAL