

BUSCH PURIFIER

Liquid Particulate Removal Unit

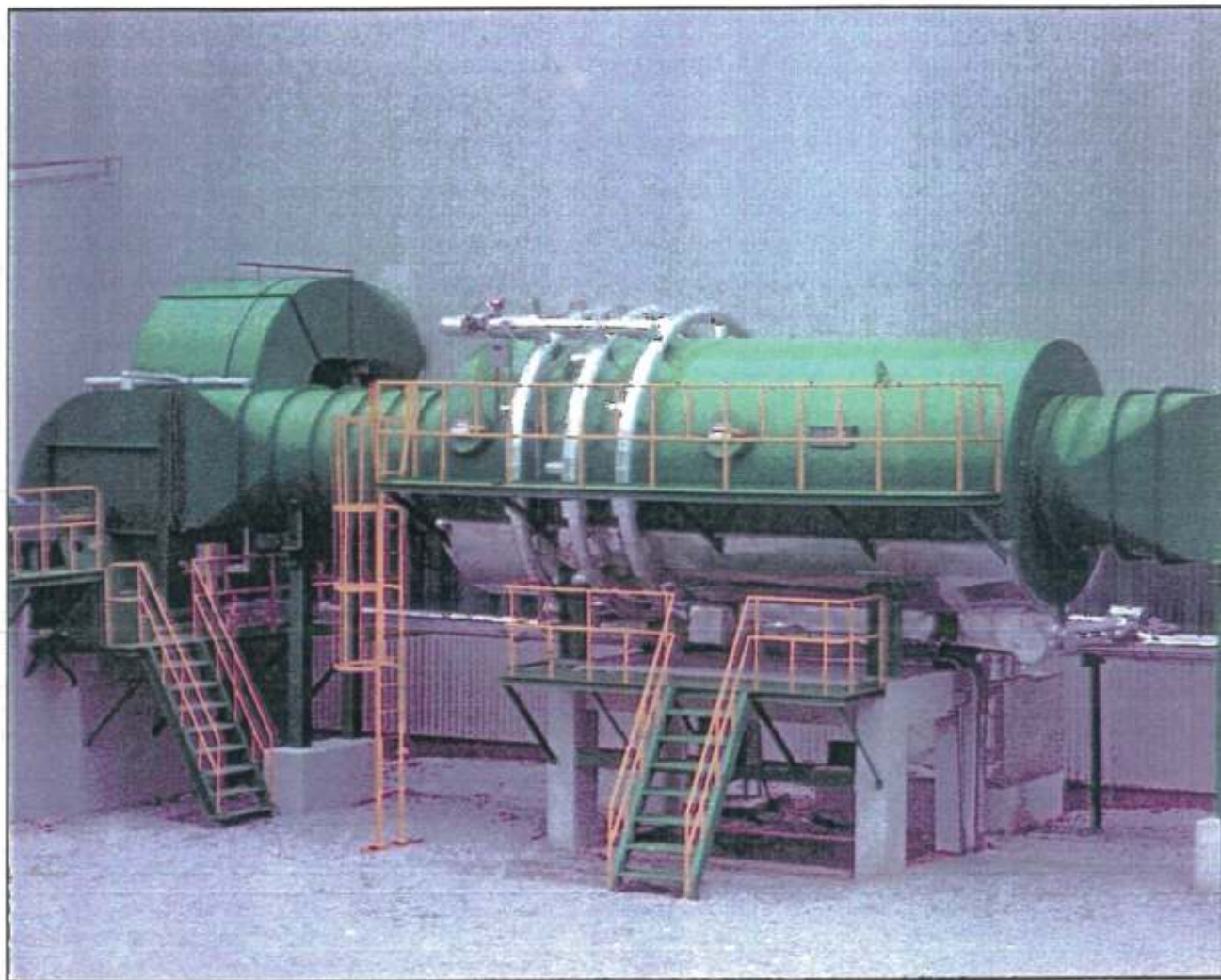

Effectively removes liquid particles from rolling mill exhaust air streams

The BUSCH PURIFIER is a high velocity, in-line cyclonic eliminator designed to collect liquid particulate from an airstream. This device is *the standard* mist removal method for rolling mills in the metals industry, cleaning millions of cubic feet of air since first introduced in 1968.

The highly effective PURIFIER which employs a two-stage design, is self-cleaning and has no moving parts. Contaminated gas enters the unit and strikes an impingement head which removes larger particles. The gas then passes through a vaned element which redirects the entrained liquid to the inside surface of the shell where it is collected and drained away.

Specific application options such as sprays for element cleaning, heat tracing and insulation of the PURIFIER shell and drains may be added as required to improve operation and maintenance characteristics.

The PURIFIER handles coolant laden air at a constant pressure drop and is highly efficient in removing most liquid particulate 10 microns in size and larger.

The BUSCH PURIFIER is the most widely used control device for rolling mill applications.

DESIGN AND CONSTRUCTION

The design of the **PURIFIER** is unique in comparison to other centrifugal mist eliminators since it has been specifically designed for rolling mill coolant removal applications. Several of the more recent modifications include relocation of drains to handle dirt contaminated coolants, redesign of drain troughs to a sloped configuration to enhance drainage of higher viscosity liquids, relocation of access doors to reduce re-entrainment and a reduction in the number of element supports to improve airflow characteristics.

Principal components of the **PURIFIER** include a vaned separating element of type 304 stainless steel and a vessel shell of minimum 1/4" steel plate. Hinged access doors are provided in each compartment. These doors are equipped with cam-lever fasteners and safety bolts to prevent accidental opening. Unit support legs are provided.

OPERATION

Separation of liquid particulate occurs in this sequence (refer to drawing below).

- 1 The liquid gas mixture enters the **PURIFIER**.
- 2 Initial separation occurs when the exhaust stream strikes a steel impingement head.
- 3 Controlled separation and coalescing of liquid particulate occurs as the stream passes through a unique element having stainless steel vanes.
- 4 The separated liquid is moved to the internal drainage surfaces by centrifugal action.
- 5 Liquid is drained, minimizing the possibility of re-entrainment.
- 6 Separated liquid is collected from the second stage and reused or wasted, depending on the process characteristics.
- 7 Cleaned gases flow through a reacceleration tube to be discharged from the exit end of the **PURIFIER** into the exhaust system.

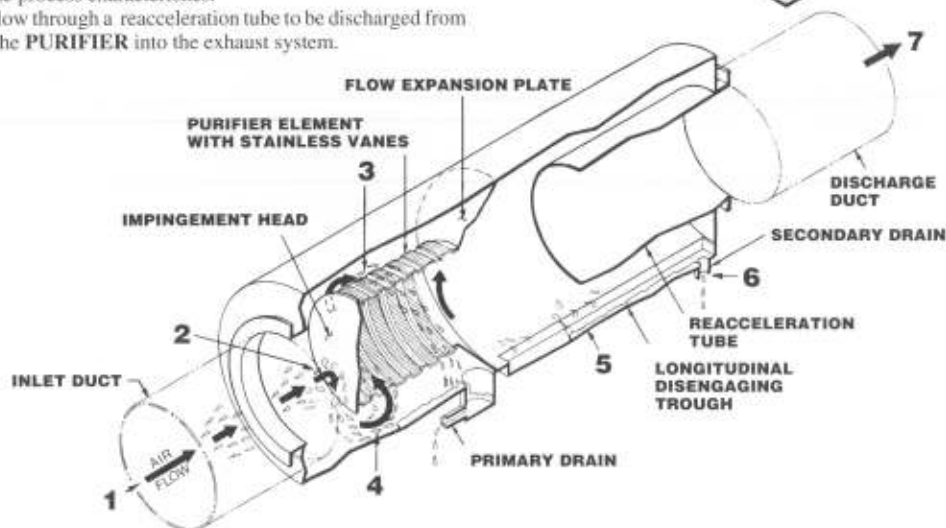

BUSCH 904 Mt. Royal Blvd.
Pittsburgh, PA 15223
412 / 487-4131
INTERNATIONAL FAX 412 / 487-7106
DIVISION OF BUSCH CO.

DIMENSIONAL DATA

SIZE	A	B	C	D
36"	3'-0"	5'-8"	14'-6"	4'-4"
42"	3'-6"	6'-4"	16'-4"	4'-8"
48"	4'-0"	7'-0"	18'-4"	5'-0"
54"	4'-6"	7'-4"	20'-0"	5'-2"
60"	5'-0"	8'-6"	22'-6"	5'-9"
66"	5'-6"	9'-6"	25'-0"	6'-3"
72"	6'-0"	10'-6"	27'-0"	6'-9"

1. Height of support legs may be varied to suit field conditions.
2. Flanges can be drilled to match mating flanges of adjacent ducts.

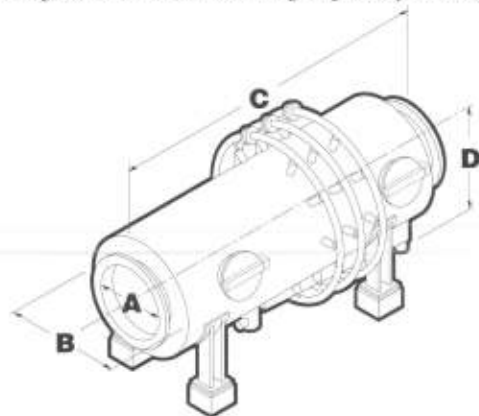

ACCESSORIES AND OPTIONS

- Support steel and platforms
- Duct and transitions
- Heat tracing and insulation
- Spray cleaning system
- Drainage units
- Alternate paint systems
- Special gasket materials
- Stainless steel construction
- Volume control and/or CO₂ containment dampers